

19" 8 PORT USB HDMI KVM DRAWER

BRAND: **PRITECH**
PART NO.: **PA-HT1908**



OVERVIEW

Featuring an integrated LCD monitor, keyboard, and touchpad in a 1U rack-mountable housing, the PA-HT1908 LCD KVM over IP Switch is a control unit that allows secure access to 8 computers from a single KVM console.

The PA-HT1908 features IP-based connectivity that allows local and remote operators to monitor and access the computers. With TCP/IP communications protocol, the PA-HT1908 can be accessed from any computer on the LAN, WAN or Internet.

It's easy to set up the PA-HT1908, just plug the cable into the appropriate port, no software needed, no complicated installation procedures, and no compatibility issues. Connect computers with compact RJ-45 connectors and Cat6 cable, transmitting distance is up to 100m.

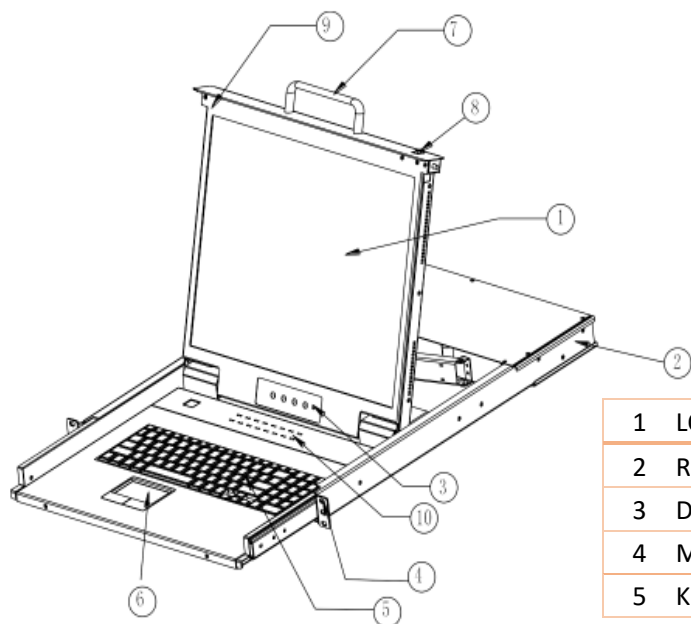

1 LCD Monitor	6 Touchpad
2 Rear Bracket Slot	7 Handle
3 Display Menu Buttons	8 Release Switch
4 Mounting Bracket	9 Display Panel
5 Keyboard	10 Port Selection Buttons

STRUCTURE

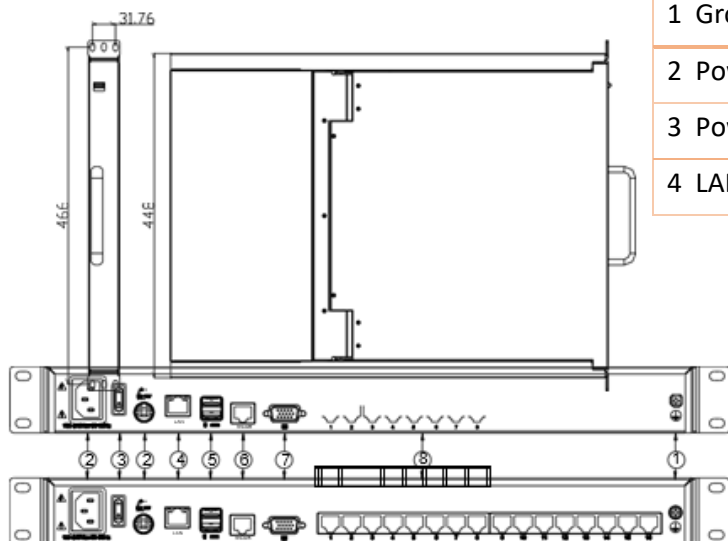
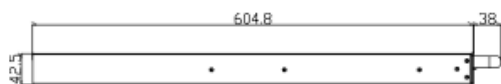

1 Ground Connection Screw	5 USB Port
2 Power input(AC or DC)	6 RS485 Port
3 Power switch	7 Console Monitor Port
4 LAN port	8 Host Port

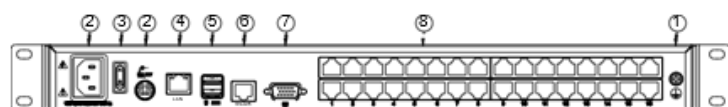
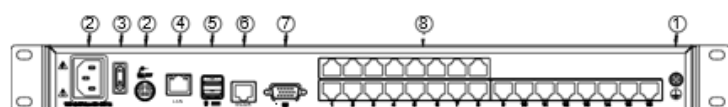

FEATURES

FEATURES

- Integrated KVM Console with 19" rackmount lcd monitor, keyboard/touchpad and 8 port KVM in a 1U height console
- Standard HDMI connection-Connect to a server or computer via standard HDMI connectors
- LCD module can be opened up to 108 degrees to provide a comfortable viewing angle
- Support computers with USB keyboard and mouse

MANAGEMENT

- Convenient computer switching via front panel LEDs, keyboard hotkey combination or on-screen-display (OSD)
- Auto scan feature for monitoring user-selected computer
- Broadcast mode--operations simultaneously performed on all selected computers
- Hot pluggable --add or remove computers without having to power down the switch
- Quickly select your computer by naming the server or inputting SN number of the server
- On-Screen Display (OSD) adjustments-Adjust the on-screen image, including: auto adjust, exit, power on/off, brightness, menu, and a power indicator

HIGH RESOLUTION

- 19" TFT LCD monitor with highlight, high definition and high resolution
- Resolution is up to 1280x 1024 60Hz

SECURITY

- Two level password security--only authorized users view and control computers
- Supports one administrator and four user accounts with a separate profile for each

HIGH PERFORMANCE TOUCHPAD

- Touchpad with scroll wheel - Eliminates the need for a separate, external mouse

KEYBOARD

- Multi-language support--English, Russian, German, French, Spanish, and Korean etc.
- Full size 99 keys keyboard with integrated number pad

WIDE COMPATIBILITY

- Multiplatform Support-Compatible with Windows, Sun, Unix and Linux
- Supports servers form Lenovo, HUA WEI, HP, IBM, Cisco and Dell, etc.

SPECIFICATIONS

MODEL		PA-HT1908
COMPUTER CONNECTION	Direct	8
	Max	8
PORT SELECTION		Pushbutton, UI interface, Web
LCD MONITOR	Mode	SXGA TFT
	View Area	19"
	Optimum Resolution	1280×1024@60Hz
	Display Color	16.7 M
	Brightness	250cd/m ² (T y p)
	Contrast Ratio	1000: 1 (T y p)
	Pixel Pitch(mm)	0.294(H) × 0.294(W)
MOUSE	X/Y Resolution	>1000 points /inch, (40 points/mm)
	Trackball	Supports trackball function
KEYBOARD		99 keys (82 keys main keyboard +17 independent number pad)
REMOTE	Remote control	KVM control (ActiveX Control)
	Management Interface	Web
	Security	DES encryption
	Optimum Resolution	1920×1080@60Hz
INPUT POWER		100V – 240Vac, 50 ~ 60Hz, <1.5A
POWER CONSUMPTION		23W
OPERATING TEMPERATURE		0 – 40°C
STORAGE TEMPERATURE		-20 – 60°C
HUMIDITY		0 – 80% RH, non-condensing
NET WEIGHT		13.4 kg
PRODUCT DIMENSION (W x D x H)		448mm×605mm×42.5mm
PACKAGE DIMENSION (W x D x H)		765mm×615mm×185mm
WARRANTY		2 Years

CONNECTION DIAGRAM

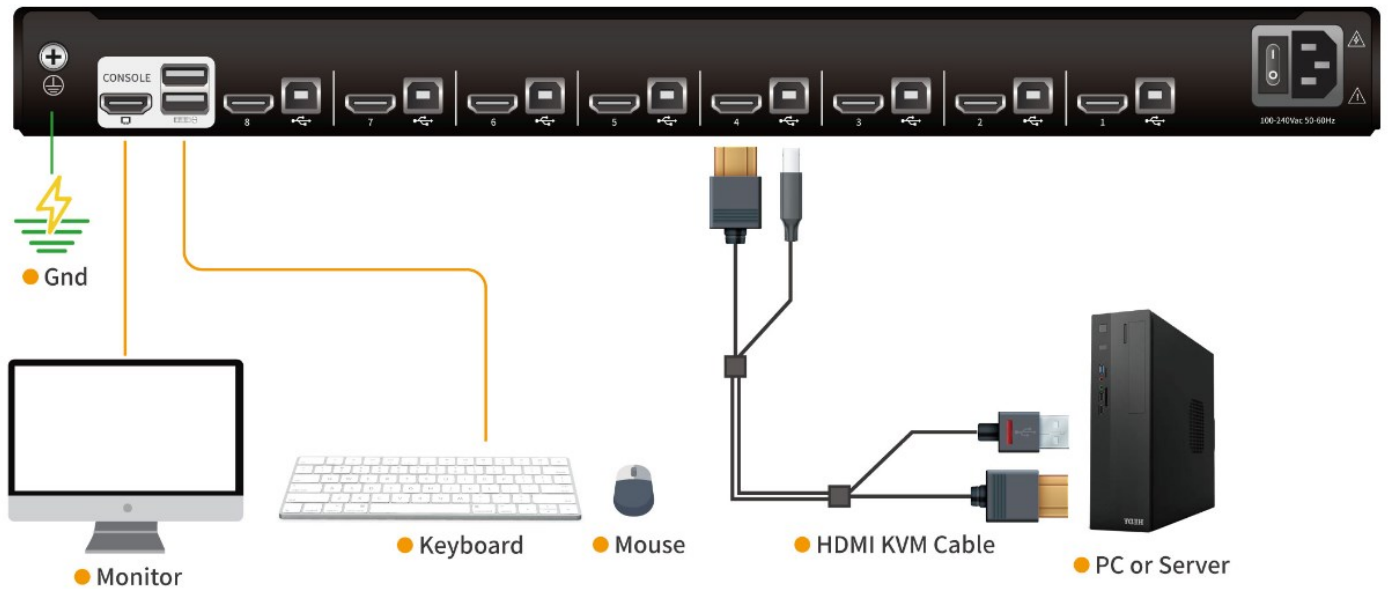

PRITECH AUTOMATION PRIVATE LIMITED

PHONE : +91 79 27702711, 09714854011

EMAIL : sales@pritechautomation.com

WEBSITE : www.pritechautomation.com



ISO 9001:2015