

PS/2 KVM Extender via CAT5: Extend to 300 Feet

XTENDEX®

Extend control up to 300 feet (91 meters) from PC or NTI switch with no loss of signal

- Sharpest and clearest VGA quality over CAT5 of any manufacturer.
- Supports two users: one local and one remote.
- Local unit provides local KVM access.
- Supports resolutions to 1920x1440.
- Allows local and remote access to network servers.
- Built-in surge protection.
- Optional external surge protection available.
- Available with optional stereo audio.
- Keep-alive keyboard/mouse emulation for flawless operation.
- Use in-house CAT5/5e/6/6a wiring to locate a keyboard, monitor and mouse remotely.
- Optional VESA mounting bracket is available for mounting the local or remote unit to the back of a flat panel monitor.



XTENDEX® ST-C5KVM-300 (Remote & Local Unit)

The XTENDEX® KVM extender provides local and remote KVM (PS/2 keyboard, PS/2 mouse and VGA monitor) access to a PC or NTI KVM switch up to 300 feet (91 meters) using CAT5/5e/6/6a UTP cable.

- **Stereo Audio**
- **CATx Surge Protector**
- **VESA Mounting Bracket**

Specifications

Local Unit

Host Connection

- Supports a PC, SUN Fire™ V20z, or NTI Switch.
- Multiplatform support: Windows 2000/XP/Vista/7/8/10, Windows Server 2000/2003/2008/2012/2016/2019, Solaris, Linux, FreeBSD, and MAC OS 9/10.
- Male 15-pin HD/male 6-pin miniDIN connectors for PC or NTI KVM switch.
- Optional stereo audio support — 3.5 mm stereo plug.

Local Access

- Crisp and clear 1920x1440 video resolution.
- Female 15-pin HD connector.
- Female 6-pin miniDIN connectors.
- Compatible with Japanese keyboard layout.
- Supports PS/2 mice including the IBM ScrollPoint mouse.
- NTI recommends using identical keyboards and mice at local and remote units.
- Optional stereo audio support — 3.5 mm stereo jack.

Video Quality Adjustment

- Video quality adjustment for different lengths of CAT5/5e/6/6a cable is done manually.

Environmental

- Operating temperature: 32 to 113°F (0 to 45°C).
- Storage temperature: -20 to 140°F (-30 to 60°C).
- Operating and Storage Relative Humidity: 17 to 90% non-condensing RH.

Dimensions

- ST-C5KVM(A)-300
 - WxDxH: 3.5x3.1x1.2 in (89x79x30 mm)
 - Weight: 1.2 lbs (0.54 kg)

Regulatory Approvals

- CE, RoHS
- TAA compliant

Warranty

- Two years

Remote Unit

- Supports resolutions up to 1920x1440; refer to the resolution chart below for resolutions at different lengths.
- Female 15-pin HD connector.
- Female 6-pin miniDIN connectors.
- Compatible with Japanese keyboard layout.
- Supports PS/2 mice including the IBM ScrollPoint mouse.
- Optional 3.5 mm stereo audio connection.

Power

- ST-C5KVM(A)-300
 - Local and remote unit: 110 or 220 VAC at 50 or 60 Hz via AC adapter.
 - Power Consumption: 10 W (each - local and remote unit).

MTBF

NTI Part #	MTBF (hrs)	NTI Part #	MTBF (hrs)
ST-C5KVM-300 (local)	88,969	ST-C5KVM-300 (remote)	86,881
ST-C5KVMA-300 (local)	82,073	ST-C5KVMA-300 (remote)	85,768

PS/2 KVM Extender via CAT5: Extend to 300 Feet

XTENDEX®

Extend control up to 300 feet (91 meters) from PC or NTI switch with no loss of signal

Configuration and Cable Illustration

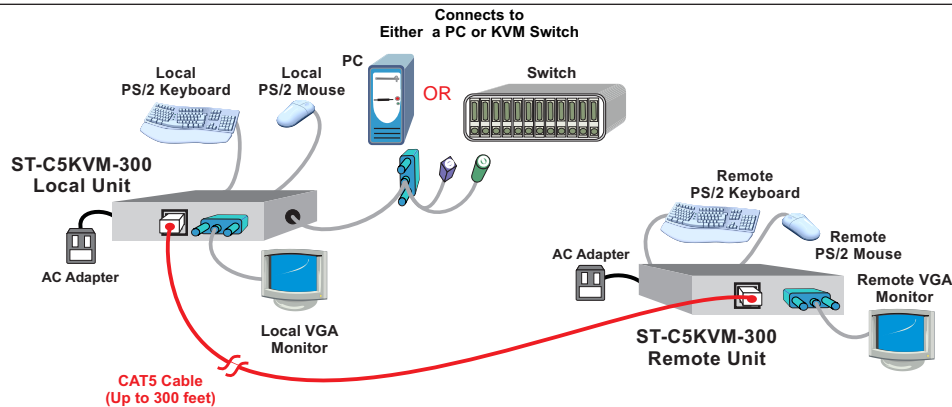

Options

Stereo Audio

- Stereo audio can be heard both locally and remotely.
- Frequency response: 20 Hz to 20 kHz, ± 1 dB.
- Signal-to-Noise Ratio (SNR): 76 dBA.
- Total Harmonic Distortion and Noise (THD+N): 0.017%.
- Stereo crosstalk: -70 dB.
- Input impedance: 10k Ohms.
- Line level output; supports multimedia speakers.
- Maximum I/O levels: 3.1Vp-p (line level).
- CD quality audio output.

CATx Surge Protector

- Protects equipment running on CATx unshielded twisted pair (UTP) cable against the effects of electrostatic discharge, faulty wiring and lightning.
- The use of two protectors on each end of the line will provide increased protection for each end against surges.
- Protected Pins: (1,2) (3,6) (4,5) and (7,8) pass through
- Impedance: 85 to 115 Ohms
- Surge Suppression: 22Vpeak @ 100A 2/10 μ s
- Dimensions WxDxH: 1x3.6x0.9 in (25x91x23 mm)

VESA Mounting Bracket

- Use to mount the local or remote unit to the back of a flat panel monitor.
- Compliant to VESA 75 and 100 mm (3 and 3.9 in) mounting hole patterns.
- Dimensions WxH (in): 9.7x4.8 (246x122 mm)
- Compatible with the local or remote unit.

ST-C5KVM-300 Distances and Resolutions for CAT5/5e/6/6a Cables

Cable	Distance (ft)	Resolution
CAT5/CAT5e Solid (UTP)	300	1280x1024 at 60 Hz
	150	1600x1200 at 60 Hz
	100	1920x1440 at 60 Hz
CAT5/5e Solid STP, CAT6 Solid UTP	300	1024x768 at 60 Hz
	150	1280x1024 at 60 Hz
	100	1600x1200 at 60 Hz
CAT6a Solid UTP	300	1024x768 at 60 Hz
	150	1280x1024 at 60 Hz
	100	1920x1200 at 60 Hz

KVM Extender Models

Supported Features	NTI Part #	Local and Remote Unit Sizes WxDxH (in)
KVM	ST-C5KVM-300	3.5x3.1x1.2
KVM + Audio	ST-C5KVMA-300	3.5x3.1x1.2